

Tutorial on TCXO's (Temperature Compensated Crystal Oscillators)

A. Temperature Stability

The temperature stability of a basic crystal oscillator can be improved by incorporating in the oscillator circuit components with temperature characteristics approximately equal to and opposite from that of the crystal as shown in Figure 1.

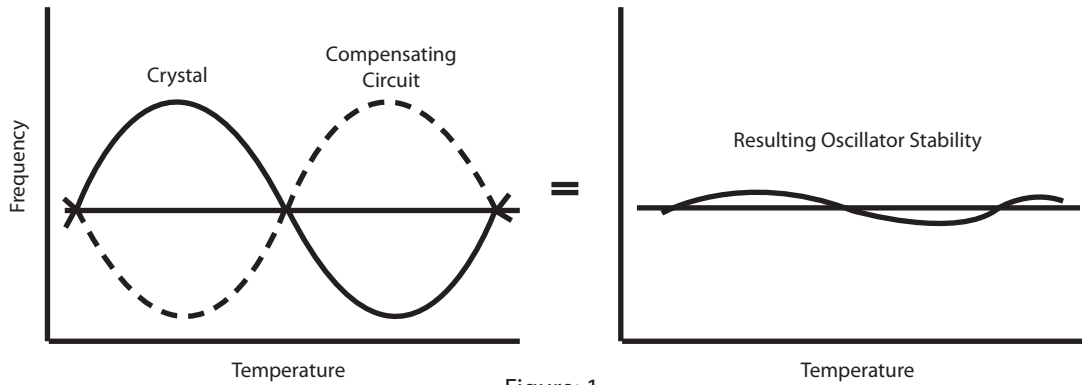

Figure: 1

The actual technique employed in all except the most simple TCXOs is based upon use of a varactor diode in series with the crystal as follows:

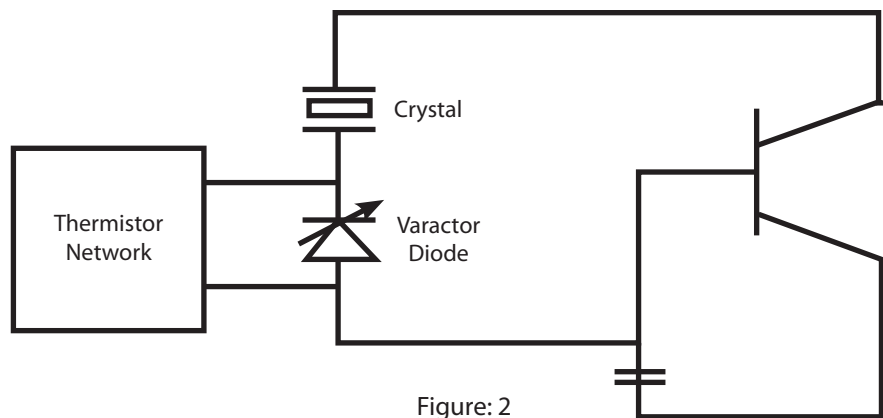

Figure: 2

A change in voltage "V" causes a change in the capacitance of the varactor diode resulting in a change in frequency of oscillation. The thermistor network is tailored to the crystal to cause voltage "V" to vary with temperature in a manner which will compensate for the crystal's frequency versus temperature characteristic. As each individual TCXO requires that its compensation network be matched to its individual crystal, the cost of a TCXO is closely related to the difficulty of the frequency versus temperature specification. The stability requirements of most TCXOs dictate compensation by means of a multiple thermistor network with several interdependent variable components thus making the solution of simultaneous equations by computer the only practical approach to temperature compensation.

When an oscillator manufacturer specifies a stability of $\pm 1 \times 10^{-6}$ over -20°C to of $+70^\circ\text{C}$, this means a total peak error of 2×10^{-6} over the temperature range, not referenced to the frequency at any specific temperature. If a reference, such as room temperature, is desired with a maximum allowable error of $\pm 1 \times 10^{-6}$ from that reference, the specification should clearly state $\pm 1 \times 10^{-6}$ over -20°C to $+70^\circ\text{C}$ referenced to the frequency at $+25^\circ\text{C}$. Further, it should be noted that the frequency versus temperature characteristic of a TCXO is not linear; thus a 2×10^{-7} total error over 0°C to $+50^\circ\text{C}$ will not produce a gradient of $2 \times 10^{-7} \div 50 = 4 \times 10^{-9}$ per $^\circ\text{C}$. Perturbations in the crystal characteristics (activity dips) make it virtually impossible to guarantee exceptional stability on a per degree basis in TCXOs.

B. Aging

In clock oscillators with moderate temperature stability, aging is usually of little consequence. However, in highly temperature stable TCXOs, crystal aging becomes a significant factor in the oscillator's overall frequency error. Therefore, TCXOs employ specially processed crystals in evacuated glass or coldweld holders.*

Many TCXO specifications include both moderate and long term aging requirements such as $\pm 1 \times 10^{-6}$ per year. The latter actually has more rapaning for a TCXO because the temperature sensitivity of the device makes it almost impossible to measure $\pm 1 \times 10^{-8}$ per day aging except under constant environmental conditions; the small day to day changes in even laboratory ambient temperatures will cause greater frequency shifts than those resulting from crystal aging over short time periods. C. Other Factors: Figure 3 illustrates the block diagram for a typical Vectron TCXO.

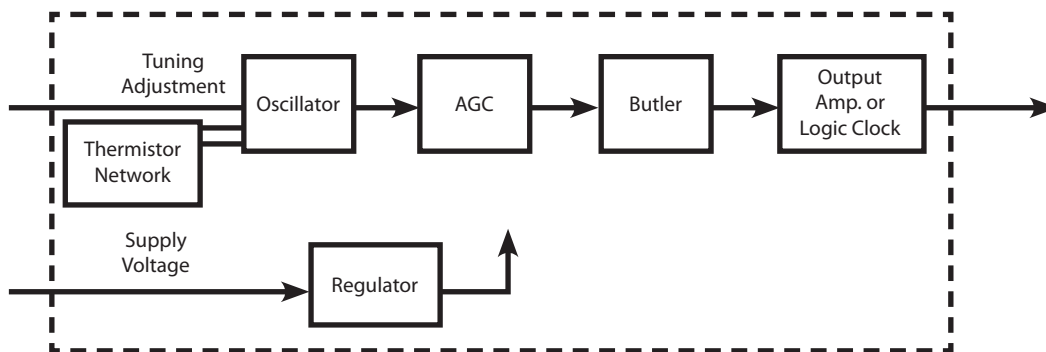

Figure: 3

It shows those elements generally not required in simple clock oscillators, but included in the proper design of a highly stable TCXO: (1) a frequency compensation network to minimize temperature sensitivity, (2) a precision crystal coupled with AGC for minimum aging, (3) a multiturn tuning adjustment permitting precise setting of frequency, (4) buffering following the oscillator to minimize the effects of external circuit changes and (5) an internal regulator to minimize the effects of voltage variation. Each of these elements is a factor in properly specified TCXO, an example of which follows.

Vectron Type:	TC-210-DAB-C507A
Frequency:	12.8 MHz
Output Level:	HCMOS
Supply Voltage:	3.3 Vdc $\pm 5\%$
Current Drain:	<15 mA
Temperature Stability:	$\pm 5 \times 10^{-7}$ over -0°C to $+70^{\circ}\text{C}$
Supply Variation:	$\pm 1 \times 10^{-7}$ percent change in supply
Aging:	2.5×10^{-6} per 10 years
Electrical Frequency Adjustment:	± 5 ppm minimum via external voltage, 0 to Vdd

For Additional Information, Please Contact

USA:

Vectron International
267 Lowell Road
Hudson, NH 03051
Tel: 1.888.328.7661
Fax: 1.888.329.8328

Europe:

Vectron International
Landstrasse, D-74924
Neckarbischofsheim, Germany
Tel: +49 (0) 7268.8010
Fax: +49 (0) 7268.801281

Asia:

Vectron International
1589 Century Avenue, the 19th Floor
Chamtime International Financial Center
Shanghai, China
Tel: +86 21 6081.2888
Fax: +86 21 6163.3598

Disclaimer

Vectron International reserves the right to make changes to the product(s) and or information contained herein without notice. No liability is assumed as a result of their use or application. No rights under any patent accompany the sale of any such product(s) or information.