

Helping Customers Innovate, Improve & Grow



Features

- 4-Pin Dip
- Fast warm-up
- TCXO replacement for better short term stability
- Frequency Range, 10 MHz to 160 MHz
- Standard frequencies, 20 MHz (SC); 13 MHz (AT)

Applications

- Base stations
- Test equipment
- Synthesizers
- Military communication equipment

Performance Specifications

Frequency Stabilities ¹ (AT-Cut Crystal-Standard - 10 to 160 MHz)						
Parameter	Min	Typical	Max	Units	Condition	Options ⁵
vs. operating temperature range (referenced to +25°C)	-100		+100	ppb	-20 to +70°C	
	-250		+250	ppb	-20 to +70°C	
	-250		+250	ppb	-40 to +85°C	
Initial tolerance	-0.5		+0.5	ppm	at time of shipment, nominal EFC V _s ±5% static Load ±5% static after 30 days of operation ≤ 60MHz after 30 days of operation ≥ 60 MHz after 30 days of operation	
vs. supply voltage change	-20		+20	ppb		
vs. load change	-20		+20	ppb		
vs. aging / day	-10		+10	ppb		
vs. aging / year	-300		+300	ppb		
	-500		+500	ppb		
Warm-up time			3	minutes	to ±200ppb of final frequency (1 hour reading) @ +25°C	
Frequency Stabilities ¹ (SC-Cut Crystal-Option - 10 to 160 MHz)						
vs. operating temperature range (referenced to +25°C)	-10		+10	ppb	-20 to +70°C	
	-25		+25	ppb	-20 to +70°C	
	-50		+50	ppb	-40 to +85°C	
Initial tolerance	-0.2		+0.2	ppm	at time of shipment, nominal EFC V _s ±5% static Load ±5% static after 30 days of operation ≤ 60 MHz; after 30 days of operation ≥60 MHz; after 30 days of operation	
vs. supply voltage change	-10		+10	ppb		
vs. load change	-10		+10	ppb		
vs. aging / day	-5.0		+5.0	ppb		
vs. aging / year	-100		+100	ppb		
vs. aging / year	-500		+500	ppb		

Performance Specifications

Supply Voltage (Vs)					
Parameter	Min	Typical	Max	Units	Condition
Supply voltage (standard)	3.135	3.3	3.465	VDC	
	4.75	5.0	5.25	VDC	
Power consumption			2.5	Watts	during warm-up
			1.0	Watts	steady state @ +25°C
RF Output					
Signal [standard]	HCMOS				
Load		15		pF	
Signal Level (Vol)			0.4	VDC	with Vs=3.3V and 15pF Load
Signal Level (Vol)			0.5		with Vs=5.0V and 15pF Load
Signal Level (Voh)	2.4			VDC	with Vs=3.3V and 15pF Load
Signal Level (Voh)	3.5				with Vs=5.0V and 15pF Load
Duty Cycle	45		55	%	@ (Voh-Vol)/2
Signal	Sine Wave				
Load		50		Ω	
Output Power @3,3V	2	5	8	dBm	50 Ω load
Putput Power @ 5.0V	5	8	11	dBm	50 Ω load
Harmonics			-30	dBm	50 Ω load
Frequency Tuning (EFC) 10 to 160 MHz					
Tuning Range	Fixed OCXO; No adjust				
Tuning Range	±5.0		±12	ppm	with AT cut crystal
	±1.0		±3	ppm	with SC cut crystal
Linearity	10%				
Tuning Slope	Positive				
Control Voltage Range	0.0	1.4	2.8	VDC	with Vs=3.3V
	0.0	2	4.0	VDC	with Vs=5.0V
Additional Parameters					
Phase Noise ³		-85	-65	dBc/Hz	1 Hz
		-110	-95	dBc/Hz	10 Hz
		-130	-120	dBc/Hz	100 Hz
		-143	-140	dBc/Hz	1 kHz
		-150	-145	dBc/Hz	10 kHz
					@ 20MHz
Weight			8.0	g	
Processing & Packing	Handling & Processing Note				
Absolute Maximum Ratings					
supply voltage (Vs)			5.5	V	with Vs=3.3 & 5.0 VDC
Output Load			50	pF	
Operable Temperature Range	-55		+85	°C	
Storage Temperature Range	-55		+85	°C	

Outline Drawing / Enclosure

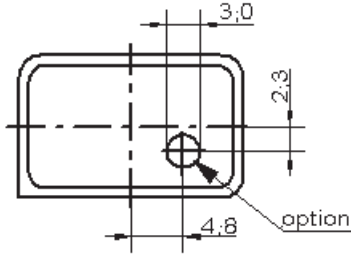
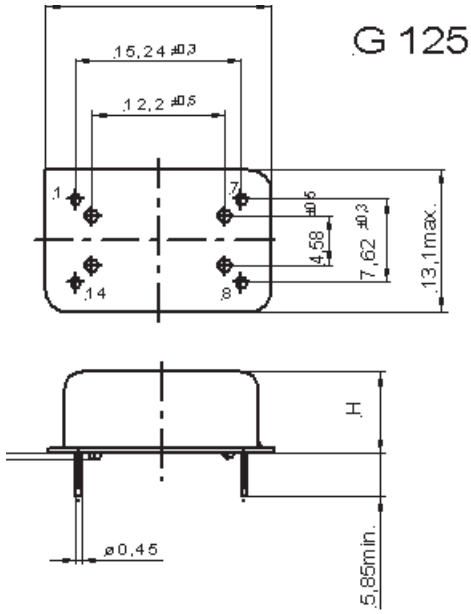

OX-400	
Height "H"	Pin Length "L"
8.5	5.85min.

Pin Connections	
1	Electronic Frequency Control Input (EFC)
7	Ground (Case)
8	RF Output
14	Supply Voltage Input

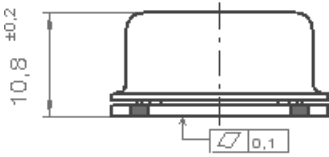
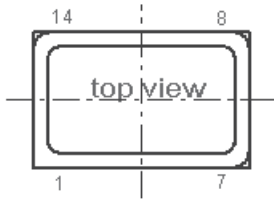

OX-401	
Height "H"	Pin Length "L"
10.8	N/A

Pin Connections	
1	Electronic Frequency Control Input (EFC)
7	Ground (Case)
8	RF Output
14	Supply Voltage Input

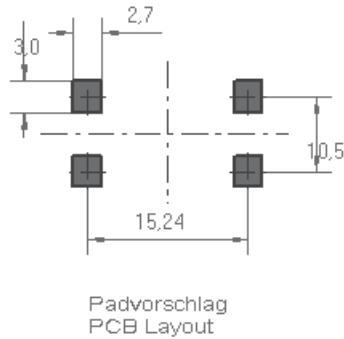
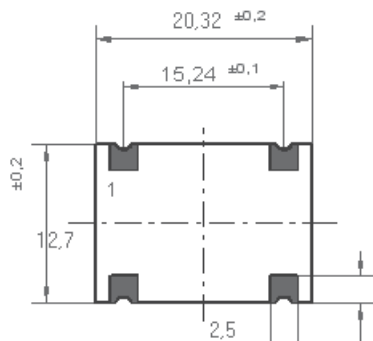

Dimensions in inches mm

Standard Shipping Method (OX-401)

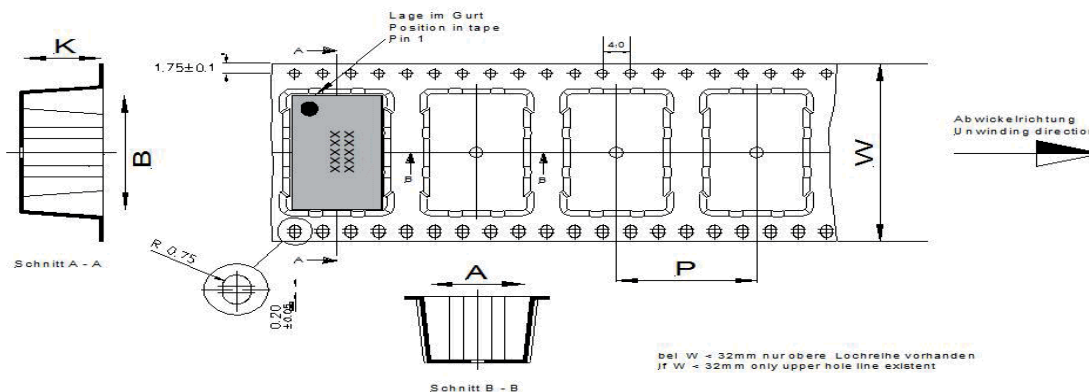

Maßangaben in mm :
A, B und K Maße vom Bauelement abhängig.
Fertigungstoleranzen entsprechen der DIN IEC 286-3

Dimension in mm :
A, B and K are dependent upon component dimensions,
production tolerance complying DIN IEC 286-3

All dimensions in millimetres unless otherwise stated.

Enclosure Type	Tape Width W (mm)	Quantity per meter	Quantity per reel	Dimension P
Typ OX-401	44	50	300	20

Recommended Reflow Profile

Solderprofile:

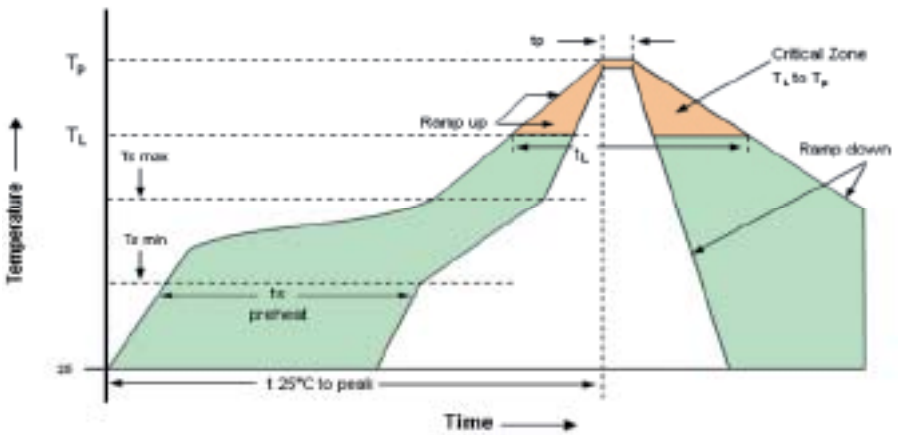

Profile Feature	Pb-Free Assembly/ Sn-Pb Assembly	Profile Feature	Pb-Free Assembly/ Sn-Pb Assembly
Average ramp-up rate (T_L to T_p)	3°C/second max.	Time 25°C to Peak Temperature	8 minutes max.
Preheat -Temperature Min T_{Smin} -Temperature Min T_{Smax} -Time (min to max) t_s	150°C 200°C 60-180 seconds	Time maintained above -Temperature (T_L) -Time (t_L)	217°C 60-150 seconds
T_{Smax} to T_L -Ramp-up Rate	3°C/second max		
Time maintained above -Temperature (T_L) -Time (t_L)	217°C 60-150 seconds	Time within 5°C of actual Peak Temperature (t_p)	20-40 seconds
Peak Temperature (T_p)	max 260°C	Ramp-down Rate	6°C/ second max

Note: All temperatures refer to topside of the package, measured on the package body surface.

Ordering Information

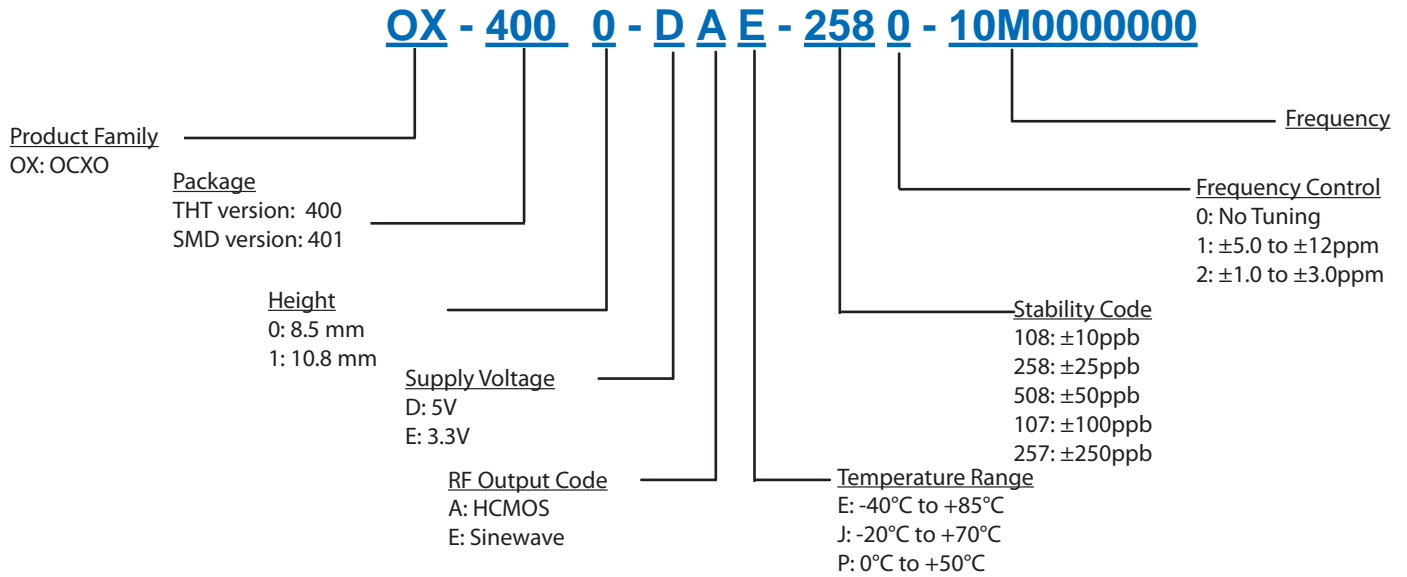

Notes:

1. Contact factory for improved stabilities or additional product options. Not all options and codes are available at all frequencies.
2. Unless other stated all values are valid after warm-up time and refer to typical conditions for supply voltage, frequency control voltage, load, temperature (25°C).
3. Phase noise degrades with increasing output frequency.
4. Subject to technical modification.
5. Contact factory for availability.

For Additional Information, Please Contact

USA:

Vectron International
267 Lowell Road
Hudson, NH 03051
Tel: 1.888.328.7661
Fax: 1.888.329.8328

Europe:

Vectron International
Landstrasse, D-74924
Neckarbischofsheim, Germany
Tel: +49 (0) 7268.801.100
Fax: +49 (0) 7268.801.282

Asia:

Vectron International
1589 Century Avenue, the 19th Floor
Chamtime International Financial Center
Shanghai, China
Tel: 86.21.6081.2888
Fax: 86.21.6163.3598

Disclaimer

Vectron International reserves the right to make changes to the product(s) and or information contained herein without notice. No liability is assumed as a result of their use or application. No rights under any patent accompany the sale of any such product(s) or information.

Rev: 9/2011