

VI TELEFILTER**Filter Specification****TFS 86****1/4****Measurement condition**

Ambient temperature: 23 °C
 Input power level: 0 dBm
 Terminating impedances
 for input: 850 Ω II - 2 pF
 for output: 850 Ω II - 2 pF

Package, pin connection and 50 Ω matching network

see page 2

Characteristics**Remark:**

Reference level for the relative attenuation a_{rel} of the TFS 86 is the minimum of the pass band attenuation a_{min} . The minimum of the pass band attenuation a_{min} is defined as the insertion loss a_e . The centre frequency f_o is the arithmetic mean value of the upper and lower frequencies at the 3 dB filter attenuation level relative to the insertion loss a_e . The nominal frequency f_N is fixed on 86,85 MHz without tolerance. The given values for the relative attenuation a_{rel} and for the group delay ripple have to be reached at the frequencies given below also if the centre frequency f_o is shifted due to the temperature coefficient of frequency TC_f in the operating temperature range and due to a production tolerance for the centre frequency f_o .

D a t a		typ. value	tolerance / limit	
Insertion loss (Reference level)	$a_e = a_{min}$	-	max. 4	dB
Nominal frequency	f_N	-	86,85	MHz
Pass band ripple $f_N \pm 13$ kHz		-	max. 1,5	dB
Relative attenuation	a_{rel}			
$f_N \pm 15$ kHz		-	max. 3	dB
$f_N - 1000$ kHz ... $f_N - 940$ kHz		-	min. 50	dB
$f_N - 940$ kHz ... $f_N - 880$ kHz		-	min. 70	dB
$f_N - 880$ kHz ... $f_N - 400$ kHz		-	min. 50	dB
$f_N - 400$ kHz ... $f_N - 120$ kHz		-	min. 40	dB
$f_N - 120$ kHz ... $f_N - 60$ kHz		-	min. 20	dB
$f_N + 60$ kHz ... $f_N + 120$ kHz		-	min. 20	dB
$f_N + 120$ kHz ... $f_N + 150$ kHz		-	min. 40	dB
$f_N + 150$ kHz ... $f_N + 400$ kHz		-	min. 30	dB
$f_N + 400$ kHz ... $f_N + 880$ kHz		-	min. 40	dB
$f_N + 880$ kHz ... $f_N + 940$ kHz		-	min. 60	dB
$f_N + 940$ kHz ... $f_N + 1000$ kHz		-	min. 40	dB
Group delay distortion	GDD			
$f_N \pm 11$ kHz		-	max. 10	µs
Intermodulation				
Intermodulation in the composit signal by $f_N \pm 60$ kHz and $f_N \pm 120$ kHz each of -20 dBm		-	max. -90	dBm
Operating temperature range			- 20 °C ... + 70 °C	
Storage temperature range			- 40 °C ... + 85 °C	
Temperature coefficient of frequency	TC		ca. - 0,036	ppm/K ²
Frequency inversion temperature			+ 20 °C ... + 30 °C	
Permissible DC voltage	V_{DC}	-	max. 10	V

Generated: _____**Checked / approved:** _____

VI TELEFILTER
 Potsdamer Straße 18
 D 14 513 TELTOW / Germany
 Tel: (+49) 3328 4784-52 / Fax: (+49) 3328 4784-30
 E-Mail: tft@telefilter.com

Vectron International, Inc.
 267 Lowell Road
 Hudson, NH 03051 / USA
 Tel: (603) 598-0070 Fax: (603) 598-0075
 E-Mail: vti@vtinh.com

VI TELEFILTER reserves the right to make changes to the product(s) and/or information contained herein without notice. No liability is assumed as a result of their use or application. No rights under any patent accompany the sale of any such product(s) or information.

Package, pin connection and 50 Ω matching network

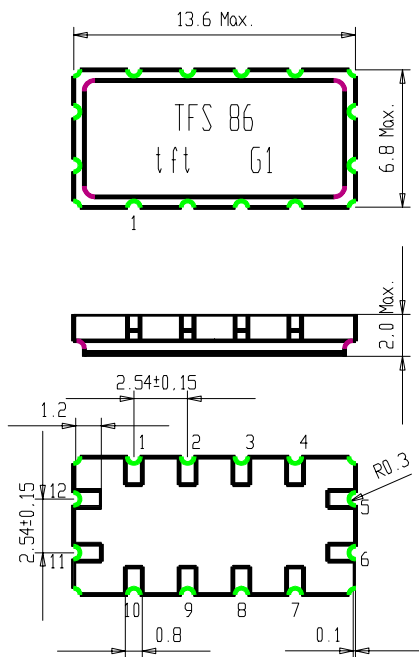

- 1 Ground
- 2 Ground
- 3 Ground
- 4 Ground
- 5 Output
- 6 Output RF-Return
- 7 Ground
- 8 Ground
- 9 Ground
- 10 Ground
- 11 Input
- 12 Input RF-Return

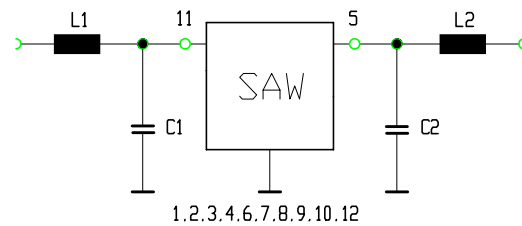
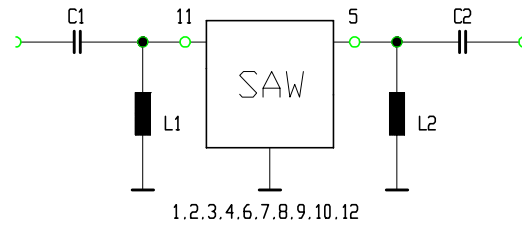

VI TELEFILTER
 Potsdamer Straße 18
 D 14 513 TELTOW / Germany
 Tel: (+49) 3328 4784-52 / Fax: (+49) 3328 4784-30
 E-Mail: tft@telefilter.com

Vectron International, Inc.
 267 Lowell Road
 Hudson, NH 03051 / USA
 Tel: (603) 598-0070 Fax: (603) 598-0075
 E-Mail: vti@vtinh.com

VI TELEFILTER reserves the right to make changes to the product(s) and/or information contained herein without notice. No liability is assumed as a result of their use or application. No rights under any patent accompany the sale of any such product(s) or information.

Stability Characteristics

After the following tests the filter shall meet the whole specification:

1. Shock: 30g, 18 ms, half sine wave, 3 shocks each plane;
DIN IEC 68 T2 - 27
2. Vibration: 10 Hz to 500 Hz, 0,075 mm or 1g respectively, 1 octave per min, 10 cycles per plan, 3 plans;
DIN IEC 68 T2 - 6
3. Damp heat:
(steady state) 90 % to 95 % rel. humidity, 40 °C, 10 days;
DIN IEC 68 - 2 - 3
4. Resistance to
solder heat (reflow): max. 2 times reflow process;
for temperature conditions refer to the attached "Air reflow temperature conditions" on sheet 4;

Packing

Tape & Reel: DIN IEC 286 - 3, with exception of value for N and minimum bending radius;
tape type II, embossed carrier tape with top cover tape on the upper side;

max. pieces of filters per reel: 1700

Tape (all dimensions in mm)

W	: 24 ± 0,3
Po	: 4 ± 0,1
Do	: 1,5 + 0,5
D1	: 1,5 + 0,5
E	: 1,75 ± 0,1
F	: 11,5 ± 0,1
G (min)	: 0,75
P2	: 2 ± 0,1
P1	: 12 ± 0,1
D1(min)	: 1,5
Ao	: 7,1 ± 0,2
Bo	: 13,9 ± 0,2

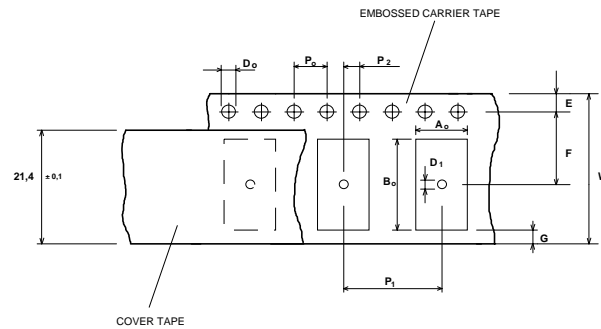

Reel (all dimensions in mm):

A	:	330
W1	:	24,4 +2
W2 (max)	:	30,4
N (min)	:	>= 90
C	:	13 ± 0,25

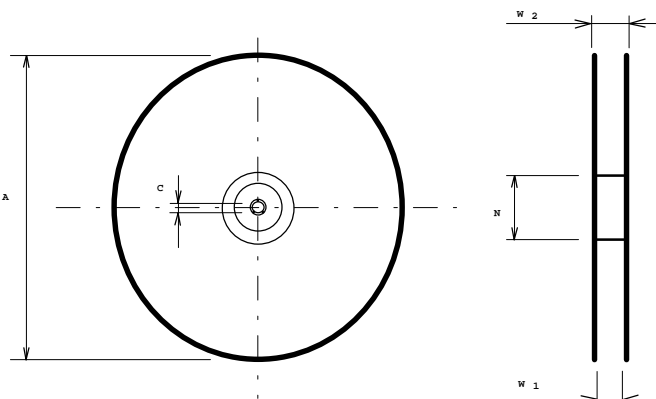

The minimum bending radius is 45 mm. The mounting surface of the filters faces the bottom side of the embossed carrier tape. The marking of the filters is able to read if the view is directed on the upper side of the carrier tape with the sprocket holes on the right side of the tape.

VI TELEFILTER

Potsdamer Straße 18

D 14 513 TELTOW / Germany

Tel: (+49) 3328 4784-52 / Fax: (+49) 3328 4784-30

E-Mail: tft@telefilter.com

Vectron International, Inc.

267 Lowell Road

Hudson, NH 03051 / USA

Tel: (603) 598-0070 Fax: (603) 598-0075

E-Mail: vti@vtinh.com

VI TELEFILTER reserves the right to make changes to the product(s) and/or information contained herein without notice. No liability is assumed as a result of their use or application. No rights under any patent accompany the sale of any such product(s) or information.

Air reflow temperature conditions

1st and 2nd air reflow profile

Name:	pre-heating periods	main-heating periods	peak temperature
Temperature:	150 °C - 170 °C	over 200 °C	255 °C ± 5 °C
Time:	60 sec. - 90 sec.	20 sec. - 25 sec.	

Chip-mount air reflow profile

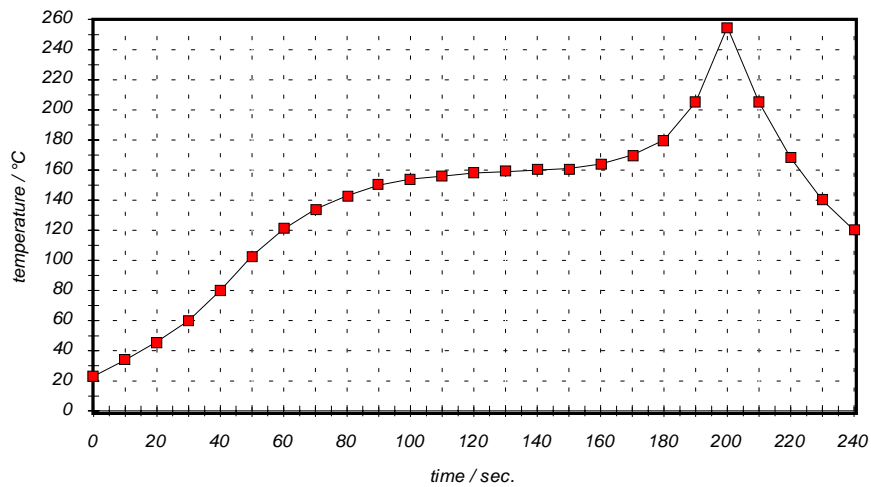

Table for temperature vs. time during the air reflow process

Tolerance of temperatures: ± 5 °C

time / sec.	temperature / °C	time / sec.	temperature / °C
0	23	140	160
10	34	150	161
20	46	160	164
30	60	170	170
40	80	180	180
50	103	190	205
60	121	195	230
70	134	200	255
80	143	205	230
90	150	210	205
100	154	215	180
110	156	220	165
120	158	230	140
130	159	240	120