

Helping Customers Innovate, Improve & Grow



Description

The VX-705 is a Voltage Control Crystal Oscillator that operates at the fundamental frequency of the internal crystal. The crystal is a high-Q quartz device that enables the circuit to achieve low phase jitter performance over a wide operating temperature range. The VX-705 is housed in an industry standard hermetically sealed LCC package and is available in tape and reel.

Features

- CMOS or LVPECL output VCXO
- Output Frequencies from 77.76 MHz to 170 MHz
- 3.3 V Operation
- Fundamental Crystal Design with Low Jitter Performance
- Output Disable Feature
- Excellent ± 20 ppm Temperature Stability,
- 0/70°C, -20/85°C or -40/85°C Operating Temperature
- Small Industry Standard Package, 5.0x7.0
- Product is free of lead and compliant to EC RoHS Directive 

Applications

- LTE
- SONET/SDH/DWDM
- Ethernet, SyncE, GE
- xDSL, PCMIA
- Digital Video
- Broadband Access
- Base Stations, Picocells
- Test and Measurement

Block Diagram

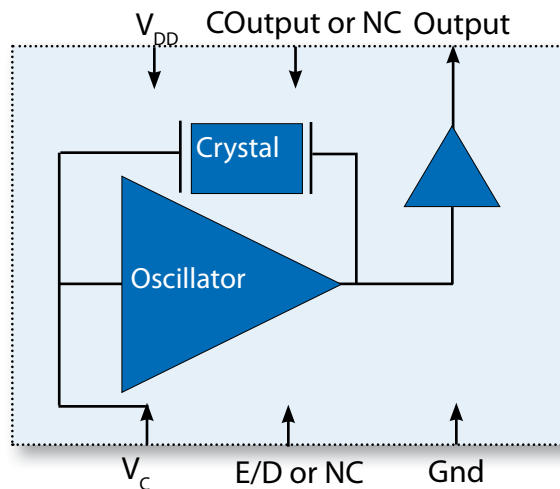

Figure 1. Block Diagram

Performance Specifications

Table 1. Electrical Performance - 3.3V CMOS					
Parameter	Symbol	Min	Typical	Maximum	Units
Supply					
Voltage ¹	V_{DD}	3.135	3.3	3.465	V
Current ²	I_{DD}		10	25	mA
Frequency					
Nominal Frequency ³	f_N	80		170	MHz
Absolute Pull Range ^{2,6} , <i>ordering option</i>	APR	± 50			ppm
Linearity ²	Lin		5		%
Temperature Stability	f_{STAB}		± 20		ppm
Outputs					
Output Logic Levels ² Output Logic High Output Logic Low	V_{OH} V_{OL}	$0.9 * V_{DD}$		$0.1 * V_{DD}$	V
Load	I_{OUT}			15	pF
Rise Time ^{2,4}	t_R			5	ns
Fall Time ^{2,4}	t_F			5	ns
Symmetry ²	SYM	45	50	55	%
Jitter, RMS ^{5,7} (12kHz to 20 MHz)	ϕJ		0.08	0.2	ps
Phase Noise ^{5,8} (122.88 MHz)					dBc/Hz
10Hz			-66		
100Hz			-98		
1kHz			-124		
10kHz			-138		
100kHz			-151		
1MHz			-158		
10MHz			-161		
Control Voltage					
Control Voltage Range for Pull Range	V_C	0.3		3.0	V
Control Voltage Input Impedance	Z_{IN}	1			M Ω
Control Voltage Modulation BW	BW	10			kHz
Output Enable/Disable ⁹ Output Enabled Output Disabled	V_{IH} V_{IL}	$0.9 * V_{DD}$		$0.1 * V_{DD}$	V
Start-Up Time	T_S			10	ms
Operating Temp, Ordering Option	T_{OP}	0/70, -20/70, -20/85, or -40/85			°C
Package Size		5.0 x 7.0 x 1.8			mm

- 1] The power supply should have by-pass capacitors as close to the supply and to ground as possible, for examples 0.1 and 0.01uF
- 2] Parameters are tested with production test circuit as shown in Figure 2.
- 3] See Standard Frequencies and Ordering Information tables for more specific information
- 4] Measured from 20% to 80% of a full output swing as shown in Figure 4.
- 5] Not tested in production, guaranteed by design, verified at qualification.
- 6] Tested with $V_C = 0.3V$ to $3.0V$ unless otherwise stated in part description
- 7] Broadband Period Jitter measured using Wavecrest SIA3300C, 90K samples, 122.80MHz Output.
- 8] Phase Noise is measured with an Agilent E5052A, 122.880MHz Output.
- 9] The Output is Enabled if the Enable/Disable is left open.

Performance Specifications

Table 2. Electrical Performance - 3.3V LVPECL

Parameter	Symbol	Min	Typical	Maximum	Units
Supply					
Voltage ¹	V_{DD}	3.135	3.3	3.465	V
Current ²	I_{DD}		50	90	mA
Frequency					
Nominal Frequency ³	f_N	77.76		170	MHz
Absolute Pull Range ^{2,6} , <i>ordering option</i>	APR	$\pm 30, \pm 50$			ppm
Linearity ²	Lin		5	10	%
Temperature Stability	f_{STAB}		± 20		ppm
Outputs					
Output Logic Levels ² Output Logic High Output Logic Low	V_{OH} V_{OL}	$V_{DD}-1.025$ $V_{DD}-1.810$	$V_{DD}-0.950$ $V_{DD}-1.700$	$V_{DD}-0.880$ $V_{DD}-1.620$	V
Rise Time ^{2,4}	t_R		0.6	1	ns
Fall Time ^{2,4}	t_F		0.6	1	ns
Symmetry ²	SYM	45	50	55	%
Jitter, RMS ^{5,8} (12kHz to 20 MHz)	ϕ_J		0.2	0.5	ps
Phase Noise ^{5,8} (155.52MHz) 10Hz 100Hz 1kHz 10kHz 100kHz 1MHz 10MHz			-60 -88 -118 -131 -145 -153 -156		dBc/Hz
Control Voltage					
Control Voltage Range for Pull Range	V_C	0.3		3.0	V
Control Voltage Input Impedance	Z_{IN}	1			M Ω
Control Voltage Modulation BW	BW	10			kHz
Output Enable/Disable ⁹ Output Enabled, Option A Output Disabled, Option A	V_{IH} V_{IL}	$0.9 \cdot V_{DD}$		$0.1 \cdot V_{DD}$	V
Start-Up Time	T_S			10	ms
Operating Temp, Ordering Option	T_{OP}	0/70, -20/70, -20/85, or -40/85			$^{\circ}C$
Package Size		5.0 x 7.0 x 1.8			mm

- 1] The power supply should have by-pass capacitors as close to the supply and to ground as possible, for examples 0.1 and 0.01uF
- 2] Parameters are tested with production test circuit below as shown in Figure 3.
- 3] See Standard Frequencies and Ordering Information tables for more specific information
- 4] Measured from 20% to 80% of a full output swing as shown in Figure 4.
- 5] Not tested in production, guaranteed by design, verified at qualification.
- 6] Tested with $V_C = 0V$ to 3.3V unless otherwise stated in part description
- 7] Broadband Period Jitter measured using Wavecrest SIA3300C, 90K samples, 155.250MHz Output.
- 8] Phase Noise is measured with an Agilent E5052A, 155.52MHz Output.
- 9] The Output is Enabled if the Enable/Disable is left open.

Test Circuits

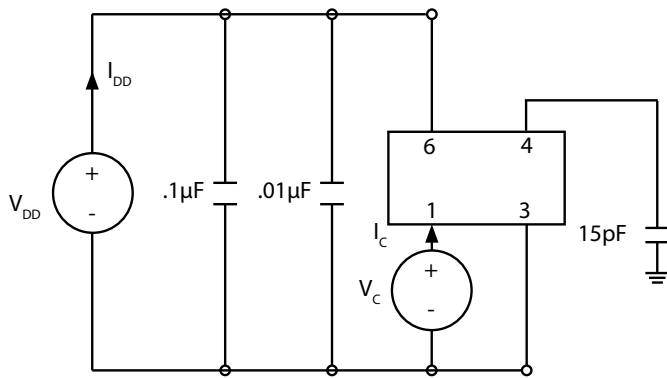
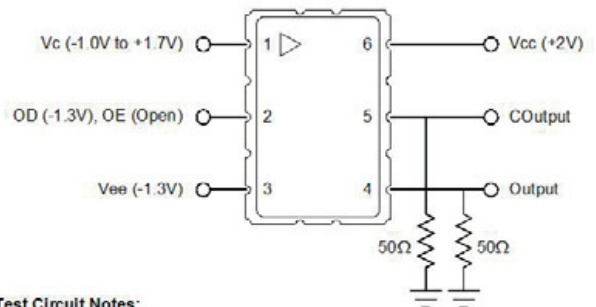

Figure 2. CMOS Test Circuit



Test Circuit Notes:

- 1) To Permit 50Ω Measurement of Outputs, all DC Inputs are Biased Down 1.3V.
- 2) All Voltage Sources Contain Bypass Capacitors to Minimize Supply Noise.
- 3) 50Ω Terminations are Within Test Equipment.

Figure 3. LVPECL Test Circuit

Waveform

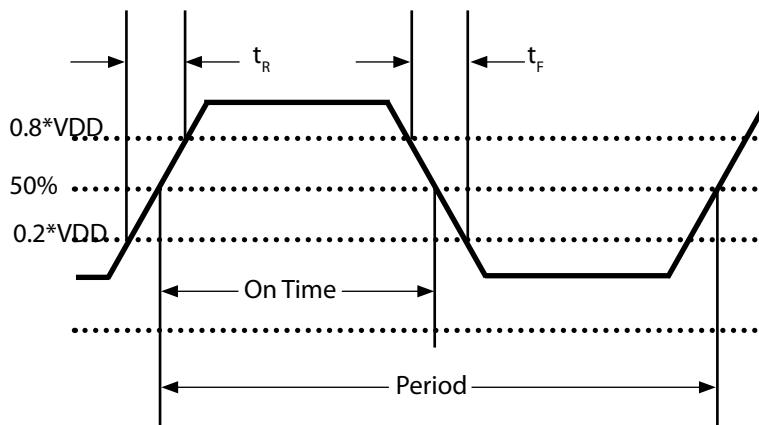

Figure 4. Output Waveform

Table 3. Absolute Maximum Ratings

Parameter	Symbol	Ratings	Unit
Power Supply	V_{DD}	0 to 6	V
Voltage Control Range	V_C	0 to V_{CC}	V
Storage Temperature	TS	-55 to 125	°C
Soldering Temp/Time	T_{LS}	260 / 20	°C / sec

Stresses in excess of the absolute maximum ratings can permanently damage the device. Functional operation is not implied at these or any other conditions in excess of conditions represented in the operational sections of this datasheet. Exposure to absolute maximum ratings for extended periods may adversely affect device reliability. Permanent damage is also possible if OD or Vc is applied before Vcc.

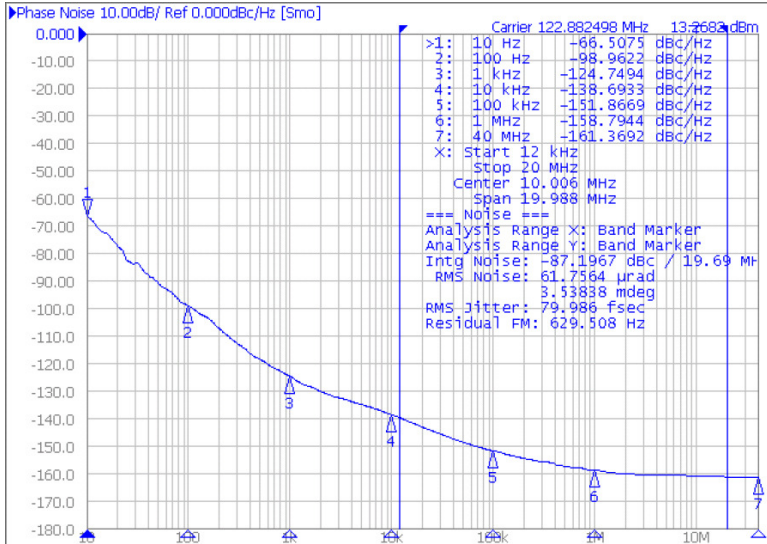

Figure 5A. Typical Phase Noise - 122.88 MHz CMOS

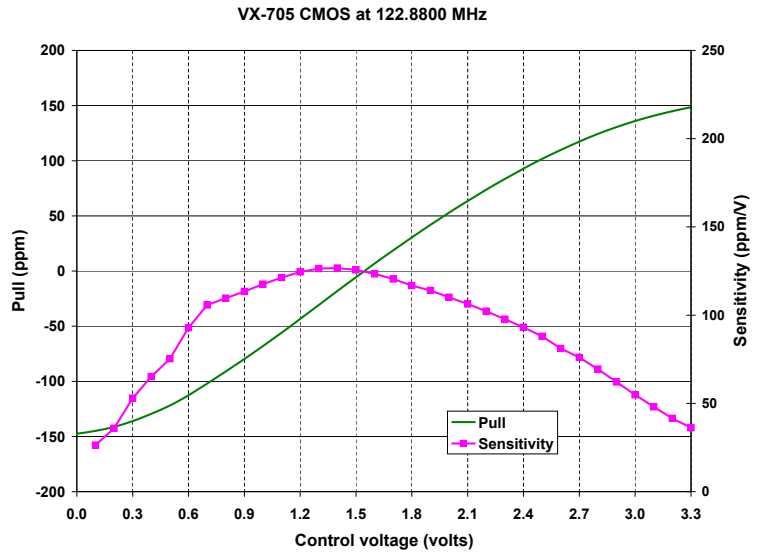

Figure 5B. Typical Gain - 122.88 MHz CMOS

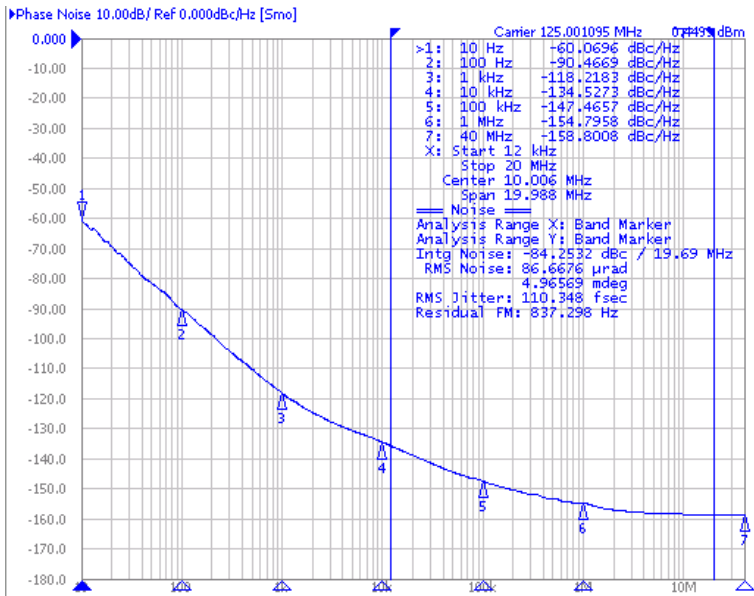

Figure 6A. Typical Phase Noise - 125.00 MHz CMOS

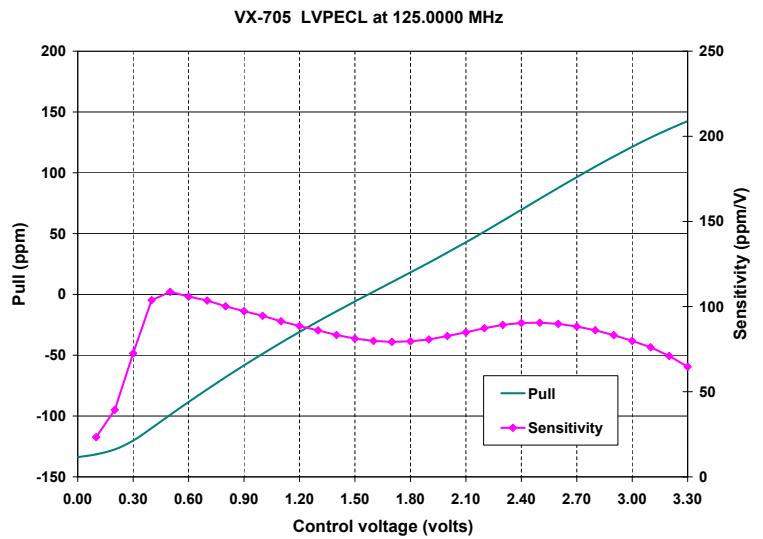

Figure 6B. Typical Gain - 125.00 MHz LVPECL

Reliability

VI qualification includes aging at various extreme temperatures, shock and vibration, temperature cycling, and IR reflow simulation. The VX-705 family is capable of meeting the following qualification tests:

Table 4. Environmental Compliance

Parameter	Conditions
Mechanical Shock	MIL-STD-883, Method 2002
Mechanical Vibration	MIL-STD-883, Method 2007
Solderability	MIL-STD-883, Method 2003
Gross and Fine Leak	MIL-STD-883, Method 1014
Resistance to Solvents	MIL-STD-883, Method 2015
Moisture Sensitivity Level	MSL 1
Contact Pads	Gold over Nickel

Handling Precautions

Although ESD protection circuitry has been designed into the VX-705 proper precautions should be taken when handling and mounting. VI employs a human body model (HBM) and a charged device model (CDM) for ESD susceptibility testing and design protection evaluation.

Table 5. ESD Ratings

Model	Minimum	Conditions
Human Body Model	500V	MIL-STD-883, Method 3015
Charged Device Model	500V	JESD22-C101

Table 6. Reflow Profile

Parameter	Symbol	Value
PreHeat Time Ts-min Ts-max	t_s	60 sec Min, 180 sec Max 150°C 200°C
Ramp Up	R_{UP}	3 °C/sec Max
Time Above 217 °C	t_L	60 sec Min, 150 sec Max
Time To Peak Temperature	T_{AMB-P}	480 sec Max

Solderprofile:

The device is qualified to meet the JEDEC standard for Pb-Free assembly. The temperatures and time intervals listed are based on the Pb-Free small body requirements. The VX-705 device is hermetically sealed so an aqueous wash is not an issue.

Termination Plating:
Electroless Gold Plate over Nickel Plate

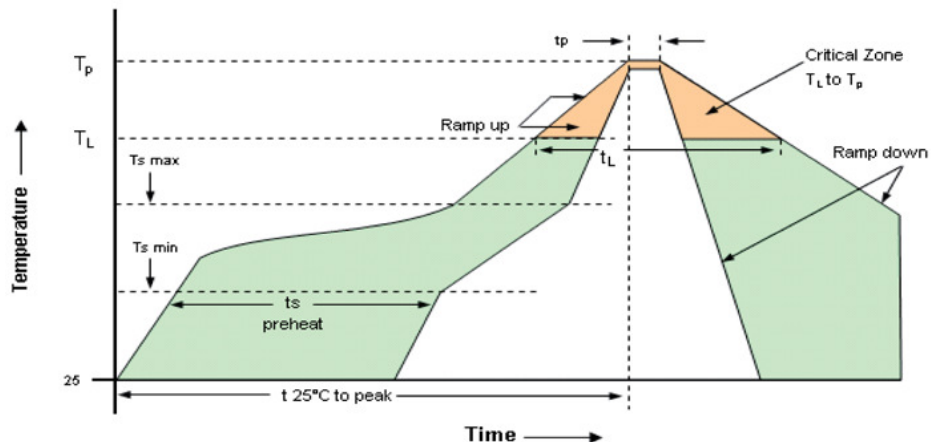

Figure 7. Recommended Reflow Profile

Outline Drawing & Pad Layout

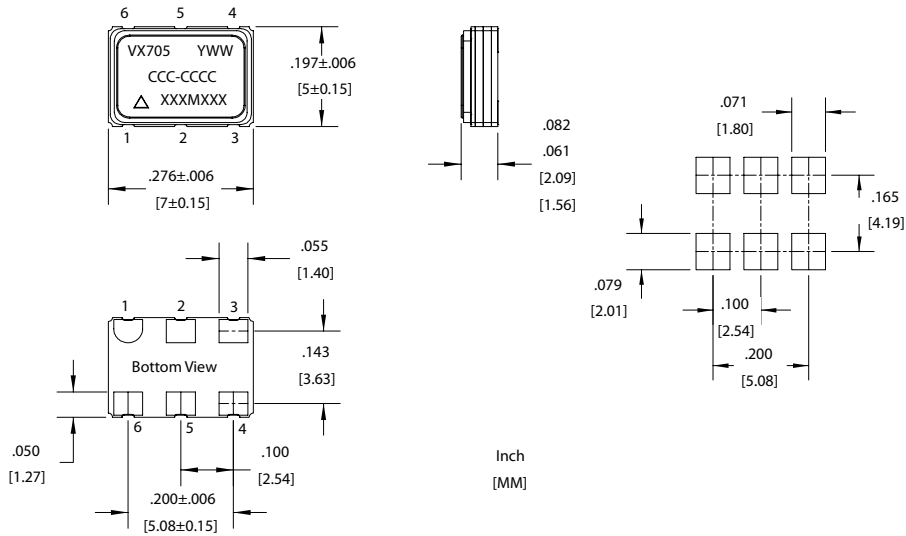

Figure 8. Outline Drawing and Pad Layout

Table 7a. Pin Out - 3.3V CMOS Option

Pin	Symbol	Function
1	V_C	VCXO Control Voltage
2	E/D	Enable Disable
3	GND	Case and Electrical Ground
4	Output	Output
5	N/C	No Connect
6	V_{DD}	Power Supply Voltage

Table 7b. Pin Out - 3.3V LVPECL Option

Pin	Symbol	Function
1	V_C	VCXO Control Voltage
2	E/D	Enable Disable **See Ordering Options**
3	GND	Case and Electrical Ground
4	Output	Output
5	COutput	Complementary Output
6	V_{DD}	Power Supply Voltage

Tape & Reel (EIA-481-2-A)

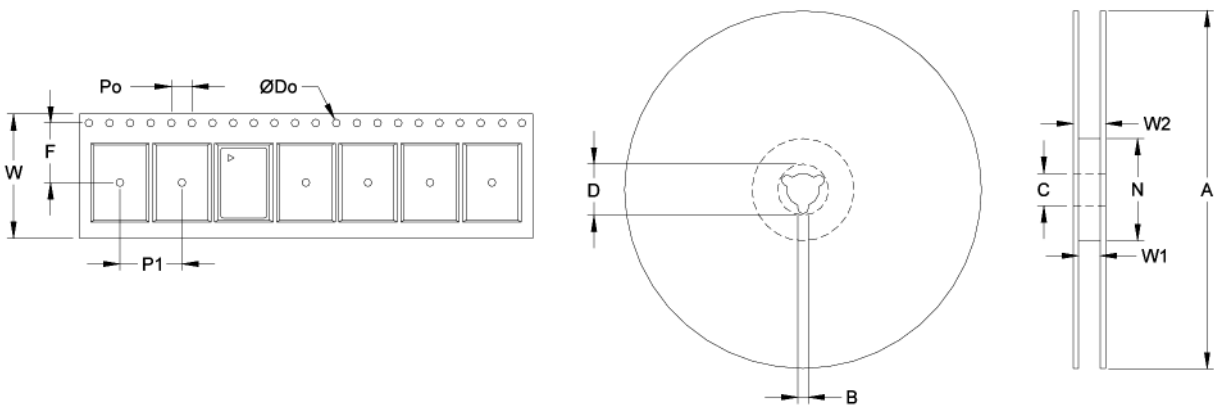

Figure 9. Tape and Reel Drawing

Table 8. Tape and Reel Information

Tape Dimensions (mm)						Reel Dimensions (mm)							
Dimension	W	F	Do	Po	P1	A	B	C	D	N	W1	W2	# Per Reel
Tolerance	Typ	Typ	Typ	Typ	Typ	Typ	Min	Typ	Min	Min	Typ	Max	
VX-705	16	5.5	1.5	4	8	178	1.78	13	20.6	55	12.4	22.4	500

Table 9. Standard Output Frequencies (MHz)						
89.60000	96.00000	100.00000	120.00000	122.88000	125.00000	127.79520
148.50000	153.6000	155.52000	156.25000	161.32800		

Ordering Information

VX-705- E A T - K X A N- 122M880000

Product

VCXO, 5x7 Package

Voltage Options

E: +3.3 Vdc

Output

A: CMOS

C: LVPECL

Temp Range

T: 0/70°C

I: -20/85°C

J: -20/70°C

E: -40/85°C

Frequency in MHz

Other (Future Use)

N: Standard

Enable/Disable

A: Enable High, Pin 2

C: Enable Low, Pin 2 (LVPECL)

X: No Enable Disable Feature, Pin 2
(No Connect Internally)

Stability

X: Standard

E: ±20 ppm Temperature Stability

Absolute Pull Range

G: ±30 ppm

K: ±50 ppm

**Note: not all combination of options are available.
Other specifications may be available upon request.*

Example: VX-705-EAT-KXAN-122M880000

For Additional Information, Please Contact

USA:

Vectron International
267 Lowell Road
Hudson, NH 03051
Tel: 1.888.328.7661
Fax: 1.888.329.8328

Europe:

Vectron International
Landstrasse, D-74924
Neckarbischofsheim, Germany
Tel: +49 (0) 7268.8010
Fax: +49 (0) 7268.801281

Asia:

Vectron International
1589 Century Avenue, the 19th Floor
Chamtime International Financial Center
Shanghai, China
Tel: 86.21.60812888
Fax: 86.21.61633598

Disclaimer

Vectron International reserves the right to make changes to the product(s) and or information contained herein without notice. No liability is assumed as a result of their use or application. No rights under any patent accompany the sale of any such product(s) or information.